

⚠ WARNING

- It is important to completely understand the operation of your bicycle's brake system. Improper use of your bicycle's brake system may result in a loss of control or an accident, which could lead to severe injury. Because each bicycle may handle differently, be sure to learn the proper braking technique (including brake lever pressure and bicycle control characteristics) and operation of your bicycle. This can be done by consulting your professional bicycle dealer and the bicycle's owners manual, and by practicing your riding and braking technique.
- Use the BR-M510 V-brake with V-brake-compatible brake levers such as the ST-M510 / BL-M510 / BL-M420 brake levers.**
- Do not use the BR-M510 V-brake with mode switching-type brake levers such as the SB-C201 / SB-C101 / BL-C101-L, as these brake levers are only for use with V-brakes with power modulator, cantilever brakes and roller brakes.**
- Obtain, read and carefully service instructions when installing parts. A loose, worn, or damaged parts may cause injury to the rider. We strongly recommend that only genuine Shimano replacement parts be used.

SERVICE INSTRUCTIONS

SI-B740A

Multi-Condition Brake System

Before use, read these instructions carefully, and follow them for correct use.

Multi-Condition Brake System

By providing superior wet weather braking performance (control and modulation), braking performance will not vary in a multitude of conditions when using this brake system.

In order to realize the best performance, we recommend that the following combination be used.

Series	DEORE
Brake lever	ST-M510/BL-M510
V-brake	BR-M510
Brake cable	

NOTE:

- By using these parts as a set, the optimum efficiency of the Multi-Condition Brake System can be realized.
- For any questions regarding methods of handling or maintenance, please contact the place of purchase.

These service instructions explain how to use and maintain the Shimano bicycle parts which have been used on your new bicycle. For any questions regarding your bicycle or other matters which are not related to Shimano parts, please contact the place of purchase or the bicycle manufacturer.

Please note: Specifications are subject to change for improvement without notice. (English)

SHIMANO
SHIMANO AMERICAN CORPORATION
One Holland Irvine CA 92618 U.S.A. Phone 949-951-5003

SHIMANO EUROPA
Industrieweg 24 NL-8071 CT Nunspeet, Holland Phone 31-3412-72222

SHIMANO INC.
3-77 Oimatsucho, Sakai, Osaka, Japan Phone 0722-23-3243

© Jun. 1999 by Shimano Inc. PIT. IZM. Printed in Malaysia

Installation of the brake lever

Use a 5 mm Allen key to install the brake lever.

Tightening torque:
6 – 8 Nm {52 – 69 in. lbs.}

Use a handlebar grip with a maximum outer diameter of 32 mm.

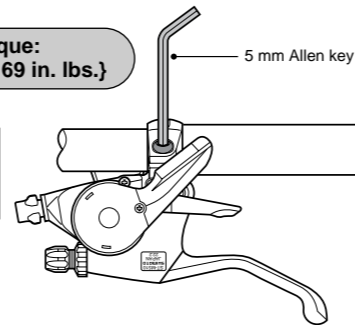

Installation of the V-brake

- Insert the stopper pin of the brake body into the center spring hole in the frame mounting boss, and then secure the brake body to the frame with the link fixing bolt.

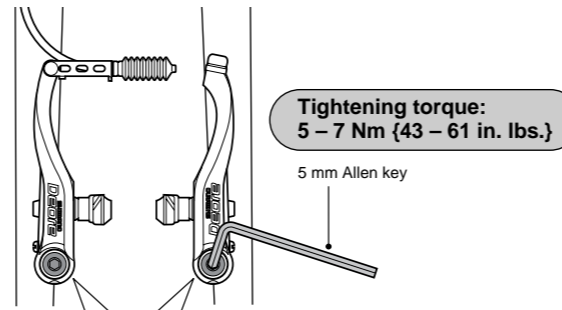

Tightening torque:
5 – 7 Nm {43 – 61 in. lbs.}

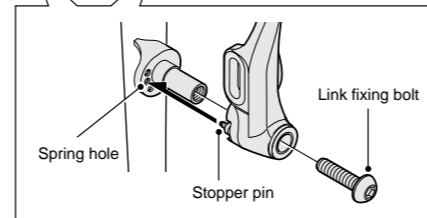

- While holding the shoe against the rim, adjust the amount of shoe protrusion by changing over the washer B (6 mm or 3 mm) so that dimension A is kept at 39 mm or more.

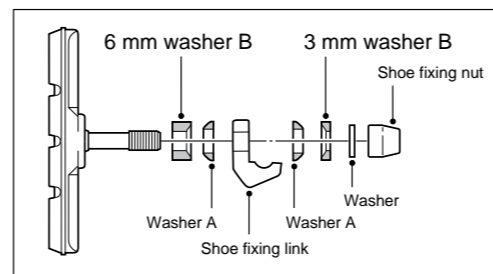
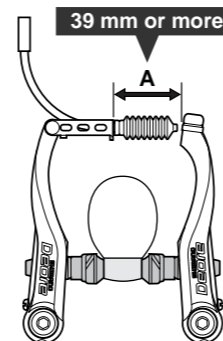

- While holding the shoe against the rim, tighten the shoe fixing nut.

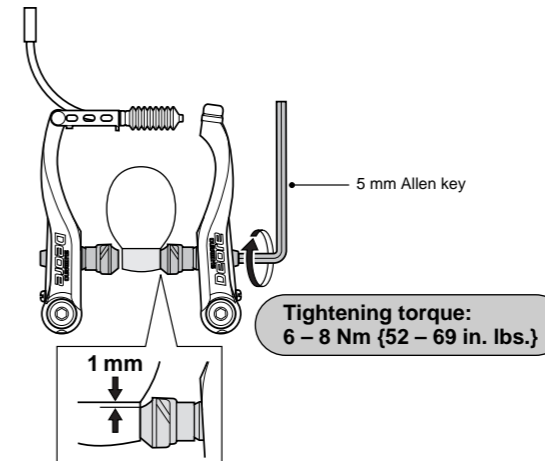

Tightening torque:
6 – 8 Nm {52 – 69 in. lbs.}

- Pass the inner cable through the inner cable lead, and after setting so that the total of the clearances between the left and right shoes and the rim is 2 mm, tighten the cable fixing bolt.

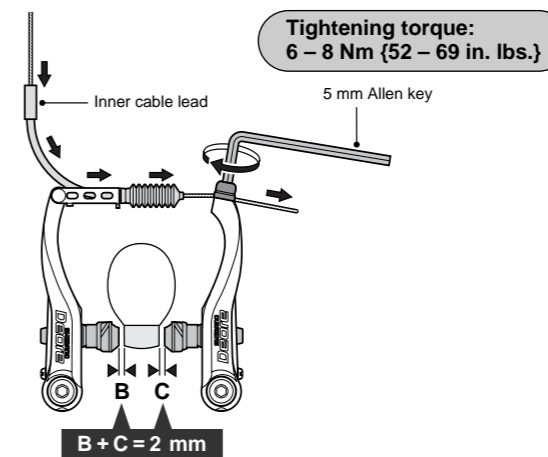

Tightening torque:
6 – 8 Nm {52 – 69 in. lbs.}

- Adjust the balance with the spring tension adjustment screws.

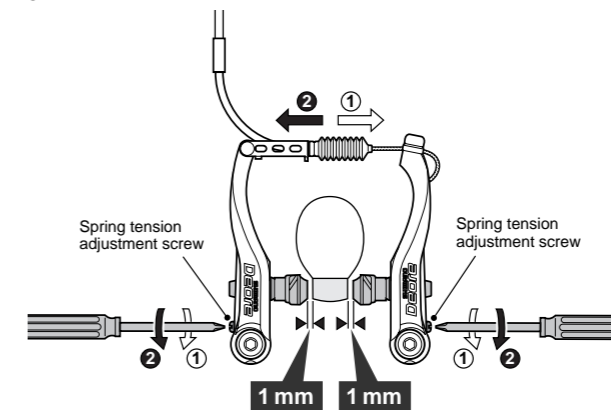

- Depress the brake lever about 10 times as far as the grip and check that everything is operating correctly and that the shoe clearance is correct before using the brakes.

